

Bag in Bag out (BIBO) Housing

Anti-Contamination banks with bags for HEPA and Activated Carbon filters



BIBO UB06/P-H



BIBO SS 1Hx1W

Applications

For exhaust air filtration of radioactive materials, pathogenic organisms, biological particles, dangerous and toxic substances. Used in genetic research, tissue culture laboratories, biosafety and animal laboratories, hospitals, operating theatres and pharmaceutical applications.

- + Fully welded and able to withstand +/- 2500 Pa pressure test
- + 100% Safe and Fully Serviceable using puncture resistant anticontamination change bags (BIBO Bags)
- + Internal Housing Edge to install BIBO Bags & Rings
- + Adjustable Eccentric Clamps ensure HEPA Filter leak free



Specifications

General characteristics

The UB and SS modular systems are suitable for the installation of different types of filters with the anti-contamination bags as physical barrier for the replacement of the filters by side access and with clamps for leak free.

Material

Housing structure made in carbon steel welded for perfect tightness and oven-baked epoxy-coated or SS304 11gauge (3.17mm) and 14 gauge (2mm) thickness which can withstand at least negative and positive pressure of 2500Pa. Removable frontal door with perimetral gasket and door locking by fold-down tie rods with wheel clamps. The housing comes with connection flanges for duct connection.

All pressurised areas are fully welded and wire brushed and burrs removed, all weld joints and filter sealing gasketing gel surface shall be smooth and aligned.

Filter clamping

After the installation in the housing, the filters are clamped by a lever action of eccentric cams in steel with knife edge and Gasket gel face of filter. The door can only be closed after the lever is clamped properly and the filter is in proper position.

Test, Decon ports and Static pressure taps

The built-in static pressure taps and ports are able to connect to measure differential pressure & conduct the challenge leak test with filter & housing and use as decontamination.

Bagging Rings & Barrier Bags

The housing shall have bagging ring on the filter access and continuous groove rib to secure the barrier bag.

The anti-contamination barrier Bags are flexible, semi translucent, weather resistant and puncture resistant. They are PVC Material of 8mils (0.2mm) thickness, 400mm Length which able to withstand and operate at -17 to 54degC which are placed inside the housing for future replacement which provide the isolation or physical barrier for the operator. The replacement of the filter element is carried out inside the polyethylene barrier bag with glove sleeve fixed by elastic elements around the double groove of the internal housing edge.

Duct Transitions

Transitions are provided if required for larger airflow Housings connecting to the Bubble tight Isolation dampers

Filters

The housings can be supplied with the filter elements The following filters can be used:
Prefilters 305x610 and 610x610 mm with depth 48
Rigid filters 285x595 and 595x595 mm with depth 290mm
HEPA filters 305x610,610x610mm with depth 292mm
Activated Carbon filters 305x610,610x610mm with depth 292mm

Options: Differential Pressure Gauges

Visual Gauge, Pressure Switch for BMS monitoring or both can be used for monitoring of system using the static pressure ports

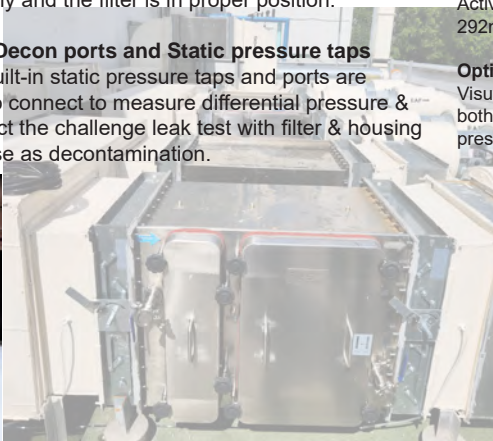

Bag in Bag out (BIBO) Housing

Anti-Contamination banks with bags for HEPA and Activated Carbon filters

Dimensions

Model / Type	1st Layer filter dimensions mm	Final Layer HEPA/ Carbon filter dimensions mm	A mm	B mm	C mm	D mm	E Upstream /downstream mm	F mm	H mm	Weight kg
UB06/P-H	610x610x48	610x610x292	755	820	628	628	558	558	906	105
UC06/H	-	610x610x292	755	820	628	628	558	558	574	65
UC03/H	305x610x292	-	755	515	628	323	558	253	574	38
SS 1Hx1W	610x610x48	610x610x292	708	-	-	708	628	628	794 / 900	130
SS 1Hx1W /x2	610x610x48	610x610x292	1416	1566	1566	1416	1336	1336	794 / 900	260

for SS 1Hx1W, w Transition Decon port & 2 BTD, 794+400+400=H1594mm. For H900mm w Decon ports & 2 ATD, 900+240=H1140mm.

Technical Data

Filters

Pre-filters/ other 48mm depth
HEPA/ Carbon filters 292mm depth

HEPA Housing, Bubble Tight damper and BIBO system

Filter Leak Test Standards

IEST RP-CC001, CC034 / EN1822 / NSF49 Biosafety Cabintry
Aerosol Challenge DEHS/ PAO leak <0.01%
ASME/ ANSI N510, 1989 1995 Reaffirmed to +/-10"w.g (2500Pa)

Enclosing Frame

Oven-baked epoxy coated in carbon steel welded
Option: Stainless Steel 304, Stainless Steel 316
11 gauge (3.175mm) & 14 gauge (2mm) thickness
Doors Right Hand
Lifting Lugs

Filter Clamping

Adjustable Lever action of eccentric Steel cams

Pressure Connections

Static Pressure ports/ Test ports

Optional

Differential Pressure Gauges (Visual), Pressure Switch (for BMS)
(Photohelic Gauge)
SS Gauge Box with SS/Metal or PU Tubings
Additional Test Ports
Transitions / Rectangle Flanges Upstream & Downstream
DN25 (1"), DN50mm (2") Decon Ports
Bubble Tight Damper (BTD) Upstream & Downstream
Air Tight Dampers (ATD) upstream & Downstream

Continuous Operating Temperature 80°C
Optional High Temperature (SS) 250 °C
Relative Humidity 90%
Recommended Final Pressure Drop 500 Pa (or Twice Initial PD)
Maximum Final Pressure Drop 700 Pa



Multi banks BIBO housing connections for higher airflow

Dimensions Drawings

Model: UB

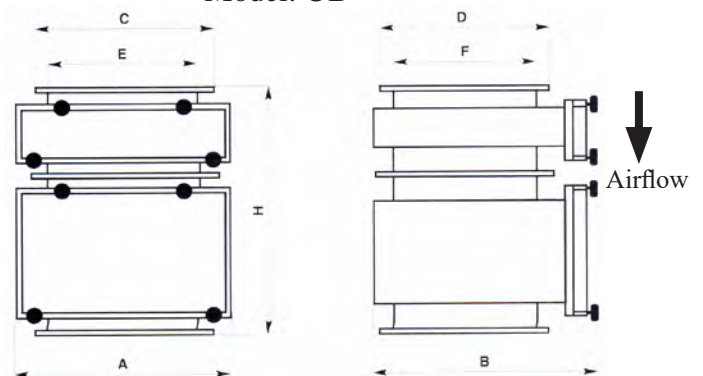

Model: UC

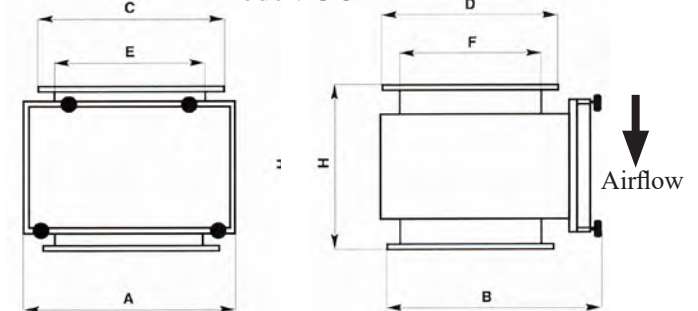

Model: SS 1Hx1

